









Thank you for purchasing this Autel diagnostic tool. This tool, manufactured to a high standard will if used according to the instructions and properly maintained give you years of trouble-free performance.



#### WARNING:

- Serious or fatal crushing injuries can occur from frame tip-over. To prevent the calibration frame from tipping over it must be secured to the ground during the assembly.
- Improper assembly of the calibration frame may result in permanent damage to the frame and may render it inoperable and/or unsafe.

## Parts List

Slide Bar 06022 	1pc	Left Pole 060023 	1pc	Right Pole 060024 	1pc	Connecting Bar 060025 	1pc
Bolt (M6x40) 060026 	8pcs	Bolt (M4x8) 060027 	4pcs	Hex L-wrench (5mm) 060028 	1pc	Hex L-wrench (3mm) 060029 	1pc

## Assemble the Target Board Holder

1

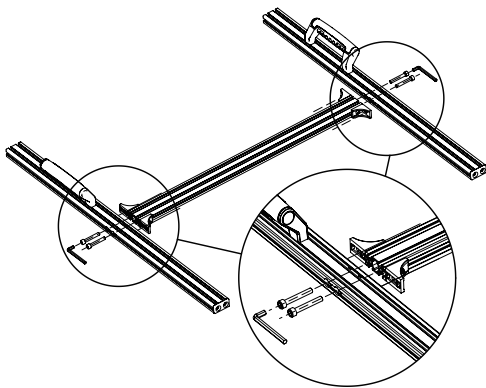

Place the left and right poles on a flat, level surface. Align the screw holes on the connecting bar with those on the left and right poles. Insert the bolts (M6x40) and tighten with the hex L-wrench (5mm).

2

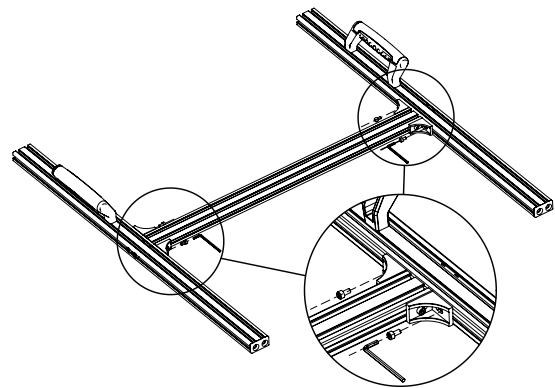

Insert the bolts (M4x8) into four screw holes on bar brackets and tighten with the hex L-wrench (3mm). Ensure the connecting bar is firmly attached to the left and right poles.

3

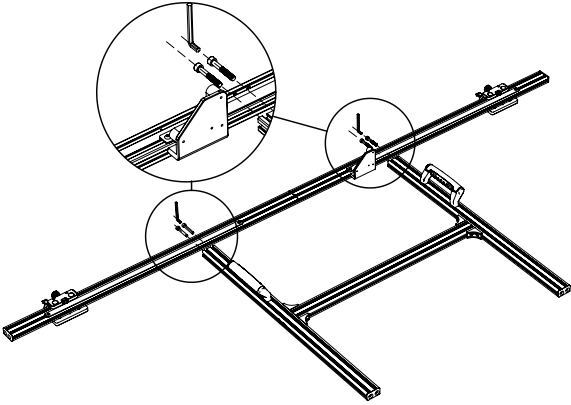

Align the four screw holes on the slide bar with those on the left and right poles. Insert bolts (M6x40) and tighten with the hex L-wrench (5mm).

4

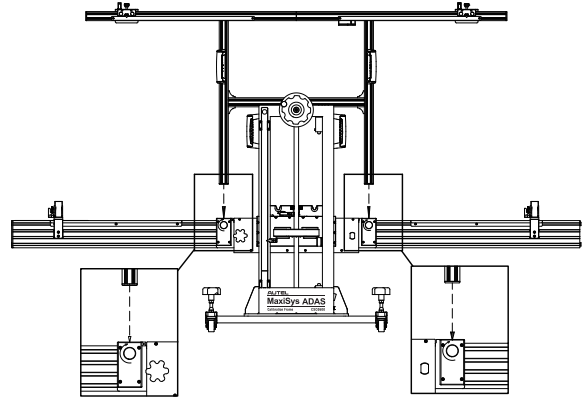

Insert the two poles into the slots on each side of the lifter of the calibration frame. Tighten the hand knobs adjacent to the slots and secure the target board holder to the lifter.

5

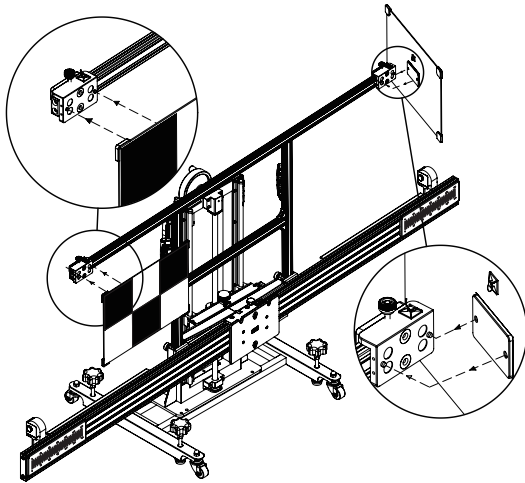

Attach the target board to the slide bar with two pins on the slider inserted into the holes on the back of the target board.

6

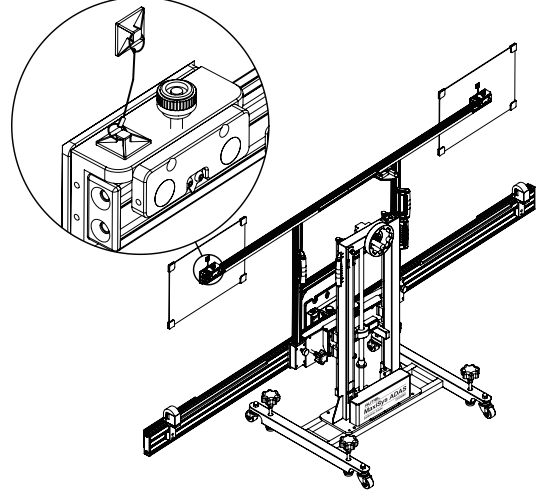

Use the locker on the slider to secure the target board to the slide bar.

7

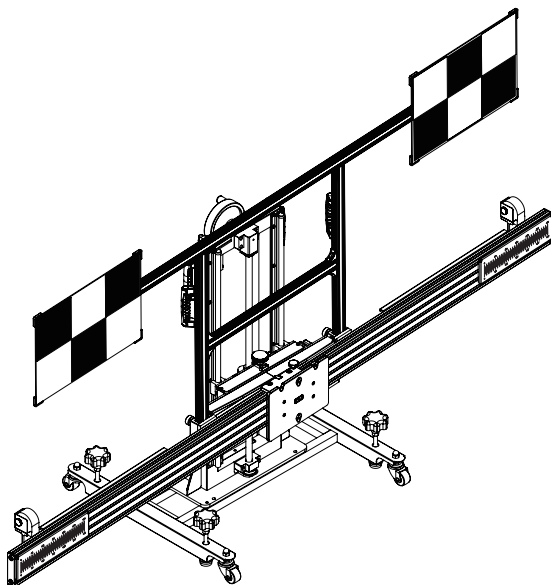

**Note:** To move target board, turn hand knob counter-clockwise to loosen board, slide it to the appropriate position on slide bar and secure target board by turning knob.